

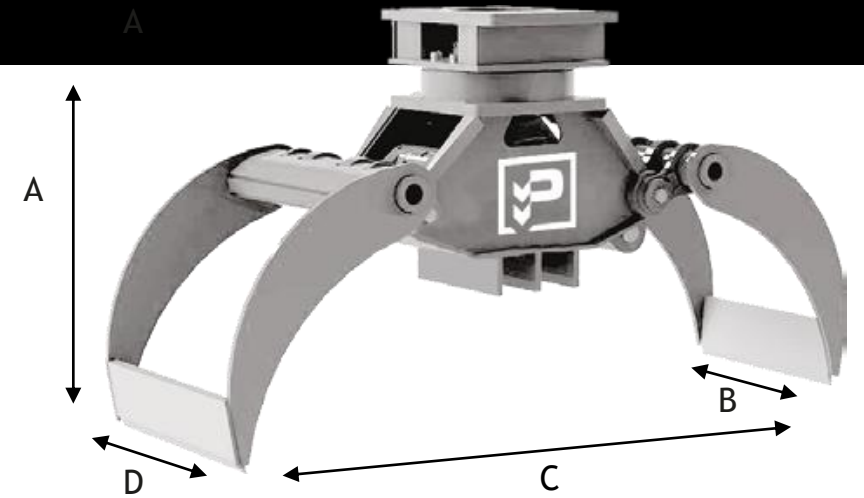

HT Range –Forestry Grabs



Technical Specifications		HT 2.3	HT 3.5	HT 5.8	HT 6.11	HT 10.16	HT 12.20	HT 16.25	HT 17.28	HT 20.28	HT 25.38	HT 30.50
Grab Weight	lb	330.7	441	441	771.6	992	1,764	2,205	2,205	3,307	3,527	3,968
Excavator Weight	lb	2,645 / 6,610	7,716 / 11,020	11,020 / 17,630	13,220 / 24,250	22,040 / 35,270	26,450 / 44,090	35,270 / 52,900	37,475 / 61,725	44,090 / 61,725	55,115 / 77,161	66,135 / 110,230
Max opening - C	in	43.3	43.3	60.6	60.6	80.7	80.7	80.7	88.6	88.6	88.6	112.2
Shell Width - B	in	15.6	15.6	19.5	19.5	17	24.8	25.3	31.6	31.6	31.6	39
Shell Width - D	in	17.5	17.5	21.5	21.5	20.1	28.7	28.9	35.5	35.5	35.5	46.8
Height - A	in	25.8	27.6	33.5	33.6	52.6	52.3	49.6	57.5	55.7	60.5	64.6
Pressure max Cylinder	psi	4,350	4,350	4,350	4,640	5,076	5,076	5,076	5,076	5,076	5,076	5,076
Oil flow Cylinder	gpm	6.6	6.6	13.21	18.5	26.4	31.7	31.7	42.2	42.2	42.2	52.8
Rotation pressure max	psi	3,046	3,046	3,046	3,046	3,046	3,046	3,046	3,046	3,046	3,046	3,046
Rotation oil flow	gpm	2.6	2.6	3.1	3.9	6.6	6.6	9.2	9.2	9.2	9.2	10.5
Min. Diameter	in	3.12	3.12	2.73	2.73	4.68	4.87	4.87	7.80	7.80	7.80	8.77
Closing force	Tonf	1.5	1.5	2.4	2.4	3.5	4.6	4.6	6.8	6.8	6.8	9

*Promove reserves the right to modify the technical data without notice



HT-7 Range –Forestry Grabs

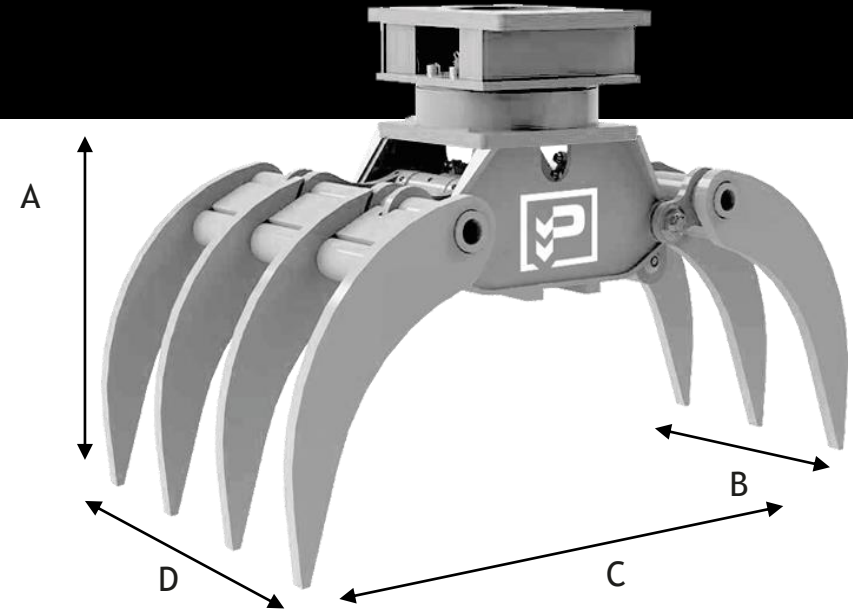

Technical Specifications		HT 2.3 -7	HT 3.5 -7	HT 5.8 -7	HT 6.11 -7	HT 10.16 -7	HT 12.20 -7	HT 16.25 -7	HT 17.28 -7	HT 20.28 -7	HT 25.38 -7
Grab Weight	lb	352.7	463	881.8	1,102	2,028	2,425	2,535	3,748	3,968	4,519
Excavator Weight	lb	2,645 / 6,610	7,716 / 11,020	11,020 / 17,630	13,220 / 24,250	22,040 / 35,270	26,450 / 44,090	35,270 / 52,900	37,475 / 61,725	44,090 / 61,725	55,115 / 77,161
Max opening - C	in	43.31	43.31	60.63	60.63	80.71	80.71	80.71	88.58	88.58	88.58
Shell Width - B	in	12.87	12.87	19.50	19.50	20.86	25.3	25.35	32.76	32.76	32.76
Shell Width - D	in	17.55	17.55	28.66	28.66	31.20	35.49	35.49	47.97	47.97	47.97
Height - A	in	29.83	30.42	39.00	42.90	52.65	52.26	52.26	60.45	60.45	60.45
Pressure max Cylinder	psi	4,350	4,350	4,350	4,640	5076	5076	5076	5076	5076	5076
Oil flow Cylinder	gpm	7.9	7.9	13.2	18.5	26.4	31.7	31.7	44.9	44.9	44.9
Rotation pressure max	psi	3,046	3,046	3,046	3,046	3,046	3,046	3,046	3,046	3,046	3,046
Rotation oil flow	gpm	2.6	2.6	3.1	3.9	6.6	6.6	9.2	9.2	9.2	9.2
Min. Diameter	in	3.12	3.12	2.73	2.73	4.68	4.87	4.87	7.80	7.80	7.80
Closing force	Tonf	1.5	1.5	2.4	2.4	3.5	4.6	4.6	6.8	6.8	6.8

*Promove reserves the right to modify the technical data without notice